

Plan View

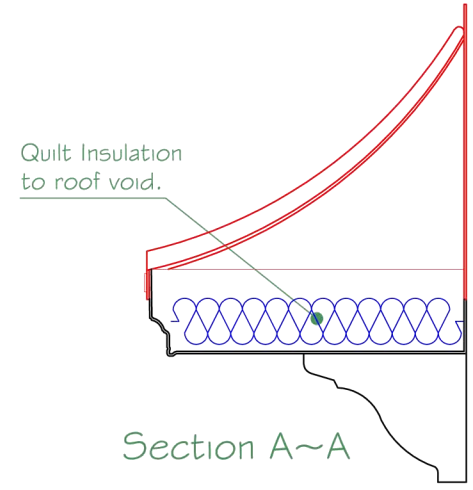

Section A~A

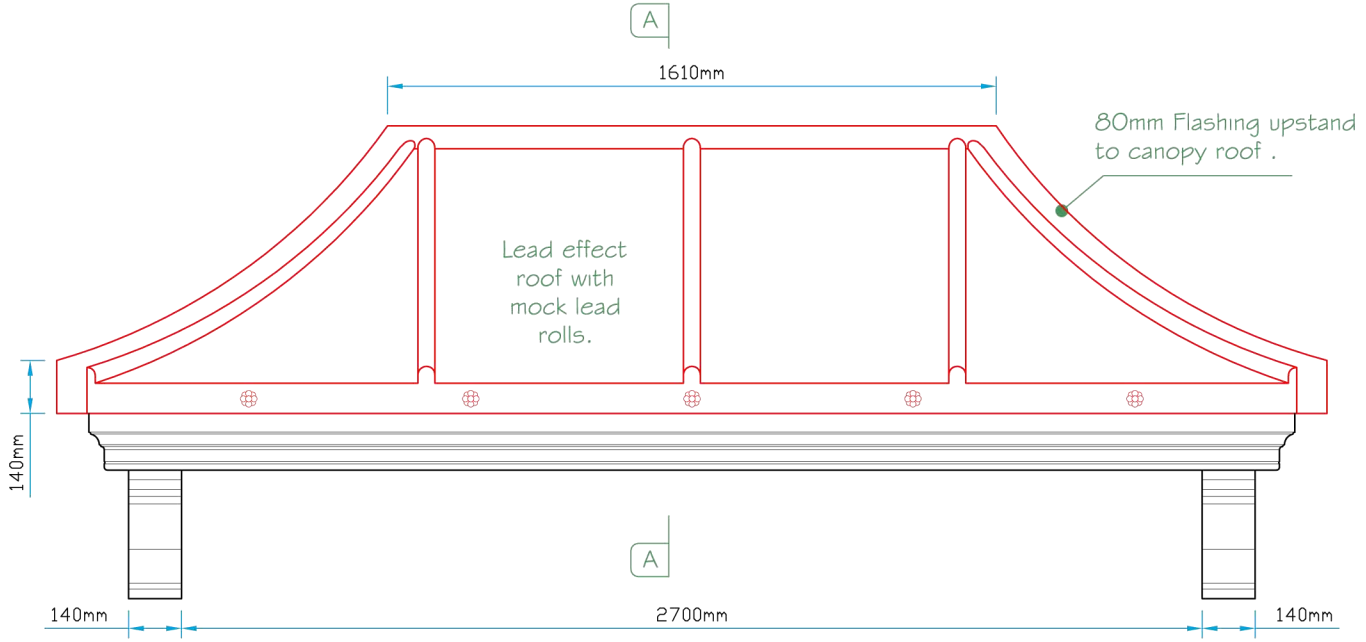

Front Elevation

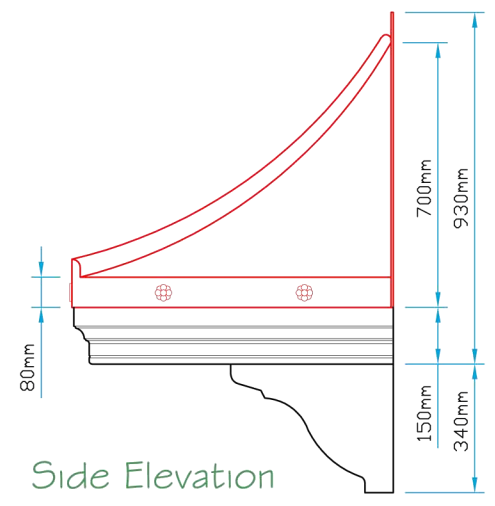

Side Elevation

 <p><b>LJM glassfibre ltd.</b> Bespoke Innovative G.R.P. Solutions</p> <p>12a Keenaghan Road, Rock, Dungannon Co Tyrone, BT70 3JL</p>		<p><b>Model:</b> Regency Apartment RH 5Q4C 3200 Canopy &amp; Mill Hill Bkt</p>	
		<p><b>Date:</b> 09/12/09</p>	
<p><b>Drw by:</b> G.J.G.    <b>Chk'd</b> G.T.    <b>App'd</b> G.T.</p>		<p><b>Scale:</b> 1:20    <b>Size:</b> A4</p>	
<p><b>Drw Title:</b> Regency Apartment RH 5Q4C 3200</p>		<p><b>Sheet No:</b> 1 of 1    <b>Rev:</b> A</p>	
		<p><b>Drw No:</b> 0068/A</p>	

Revision	
A	Drw General update    09/12/05